

# User's Information Guide

## Condensing Gas Furnaces Fan Assisted Combustion System Upflow/ Horizontal and Downflow/ Horizontal

**IMPORTANT:** Users **MUST** read all instructions in the manual. All manuals **MUST** be kept for future reference.

### SAFETY SECTION

Safety signal words are used to designate a degree or level of seriousness associated with a particular hazard. The signal words for safety markings are **WARNING** and **CAUTION**.

- a. **WARNING** indicates a potentially hazardous situation which, if not avoided, could result in death or serious injury.
- b. **CAUTION** indicates a potentially hazardous situation which, if not avoided, may result in minor or moderate injury. It is also used to alert against unsafe practices and hazards involving only property damage.

#### **WARNING**

If the information in this manual is not followed exactly, a fire or explosion may result causing property damage, personal injury or loss of life.

- Do **NOT** store or use gasoline or other flammable vapors and liquids or combustible materials in the vicinity of this or any other appliance.
- **WHAT TO DO IF YOU SMELL GAS**
  - Do not try to light any appliance.
  - Do not touch any electrical switch; do not use any phone in your building.
  - Immediately call your gas supplier from a neighbor's phone. Follow the gas supplier's instructions.
  - If you cannot reach your gas supplier, call the fire department.
- **DO NOT RELY ON SMELL ALONE TO DETECT LEAKS. DUE TO VARIOUS FACTORS, YOU MAY NOT BE ABLE TO SMELL FUEL GASES.**
  - U.L. recognized fuel gas and CO detectors are recommended in all applications, and their installation should be in accordance with the manufacturer's recommendations and/or local laws, rules, regulations, or customs.
- Installation and service must be performed by a qualified installer, service agency or the gas supplier.

### Contents

|                            |    |
|----------------------------|----|
| Safety Section             | 1  |
| General Information        | 3  |
| To Start the Furnace       | 4  |
| Proper Maintenance         | 6  |
| The Problem Solver         | 8  |
| Regular Dealer Maintenance | 9  |
| Warranty                   | 11 |

#### **WARNING**

##### EXPLOSION HAZARD

DO NOT USE THIS UNIT IF ANY PART HAS BEEN UNDER WATER. A FLOOD DAMAGED UNIT IS EXTREMELY DANGEROUS. ATTEMPTS TO USE THE FURNACE CAN RESULT IN FIRE OR EXPLOSION. A QUALIFIED SERVICE AGENCY SHOULD BE CONTACTED TO INSPECT THE FURNACE AND TO REPLACE ALL GAS CONTROLS, CONTROL SYSTEM PARTS, ELECTRICAL PARTS THAT HAVE BEEN WET OR THE FURNACE IF DEEMED NECESSARY. FAILURE TO FOLLOW THIS WARNING COULD RESULT IN PROPERTY DAMAGE, PERSONAL INJURY OR DEATH.

#### **WARNING**

##### EXPLOSION HAZARD

IN THE EVENT THAT ELECTRICAL, FUEL OR MECHANICAL FAILURES OCCUR, THE OWNER SHOULD IMMEDIATELY TURN OFF THE GAS SUPPLY AT THE MANUAL GAS SHUT OFF VALVE LOCATED ON THE SUPPLY GAS PIPING COMING INTO THE FURNACE, TURN OFF THE ELECTRICAL POWER TO THE FURNACE, AND CONTACT SERVICER. FAILURE TO FOLLOW THIS WARNING COULD RESULT IN PROPERTY DAMAGE, PERSONAL INJURY OR DEATH.

# User's Information

## **⚠ WARNING**

**EXPLOSION HAZARD**  
SHOULD OVERHEATING OCCUR, OR THE GAS SUPPLY FAIL TO SHUT OFF, SHUT OFF THE MANUAL GAS VALVE TO THE FURNACE BEFORE SHUTTING OFF THE ELECTRICAL SUPPLY.  
FAILURE TO FOLLOW THIS WARNING COULD RESULT IN PROPERTY DAMAGE, PERSONAL INJURY OR DEATH.

## **⚠ WARNING**

**SAFETY HAZARD**  
IMPROPER INSTALLATION, ADJUSTMENT, ALTERATION, SERVICE OR MAINTENANCE CAN CAUSE INJURY OR PROPERTY DAMAGE. FOR ASSISTANCE OR ADDITIONAL INFORMATION CONSULT A QUALIFIED INSTALLER, SERVICE AGENCY OR THE GAS SUPPLIER.  
FAILURE TO FOLLOW THIS WARNING COULD RESULT IN PROPERTY DAMAGE, PERSONAL INJURY OR DEATH.

The following warning complies with State of California law, Proposition 65.

## **⚠ WARNING**

**THIS PRODUCT CONTAINS FIBERGLASS WOOL INSULATION!**

Fiberglass dust and ceramic fibers are believed by the State of California to cause cancer through inhalation. Glasswool fibers may also cause respiratory, skin, or eye irritation.

### **PRECAUTIONARY MEASURES**

- Avoid breathing fiberglass dust.
- Use a NIOSH approved dust/mist respirator.
- Avoid contact with the skin or eyes. Wear long-sleeved, loose-fitting clothing, gloves, and eye protection.
- Wash clothes separately from other clothing: rinse washer thoroughly.
- Operations such as sawing, blowing, tear-out, and spraying may generate fiber concentrations requiring additional respiratory protection. Use the appropriate NIOSH approved respirator in these situations.

### **FIRST AID MEASURES**

- Eye Contact** – Flush eyes with water to remove dust. If symptoms persist, seek medical attention.
- Skin Contact** – Wash affected areas gently with soap and warm water after handling.

## **⚠ WARNING**

**CARBON MONOXIDE POISONING HAZARD**  
FAILURE TO FOLLOW THE INSTALLATION AND OPERATION INSTRUCTIONS FOR THE VENTING SYSTEM'S OPERATION COULD RESULT IN CARBON MONOXIDE POISONING OR DEATH.

## **⚠ WARNING**

**ELECTRIC SHOCK HAZARD**  
BODILY INJURY CAN RESULT FROM HIGH VOLTAGE ELECTRICAL COMPONENTS, FAST MOVING FANS, AND COMBUSTIBLE GAS. DURING INSTALLATION AND SERVICING, THE ELECTRICAL SUPPLY MUST BE DISCONNECTED AND THE MAIN GAS VALVE MUST BE TURNED OFF.  
FAILURE TO FOLLOW THIS WARNING COULD RESULT IN PROPERTY DAMAGE, PERSONAL INJURY OR DEATH.

## **⚠ WARNING**

**BURN HAZARD**  
DO NOT ATTEMPT TO MANUALLY LIGHT THE FURNACE.

## **⚠ WARNING**

**EXPLOSION HAZARD**  
PROPANE GAS IS HEAVIER THAN AIR AND MAY COLLECT IN ANY LOW AREAS OR CONFINED SPACES. IN ADDITION, ODORANT FADE MAY MAKE THE GAS UNDETECTABLE EXCEPT WITH A WARNING DEVICE. IF THE GAS FURNACE IS INSTALLED IN A BASEMENT, AN EXCAVATED AREA OR A CONFINED SPACE, IT IS STRONGLY RECOMMENDED TO CONTACT A GAS SUPPLIER TO INSTALL A GAS DETECTING WARNING DEVICE IN CASE OF A GAS LEAK. THE MANUFACTURER OF YOUR FURNACE DOES NOT TEST ANY DETECTORS AND MAKES NO REPRESENTATIONS REGARDING ANY BRAND OR TYPE OF DETECTOR.

## **⚠ CAUTION**

Never operate your unit for either heating or cooling with filters removed.

## **⚠ WARNING**

**RISK OF ELECTRIC SHOCK:**  
THESE SERVICING INSTRUCTIONS ARE FOR USE BY QUALIFIED PERSONNEL ONLY. TO REDUCE THE RISK OF ELECTRIC SHOCK, DO NOT PERFORM ANY SERVICING OTHER THAN THAT CONTAINED IN THESE OPERATING INSTRUCTIONS UNLESS YOU ARE QUALIFIED TO DO SO.  
FAILURE TO FOLLOW THIS WARNING COULD RESULT IN PROPERTY DAMAGE, PERSONAL INJURY OR DEATH.

## **⚠ WARNING**

**SAFETY HAZARD**  
IMPROPER INSTALLATION, ADJUSTMENT, ALTERATION, SERVICE OR MAINTENANCE CAN CAUSE INJURY OR PROPERTY DAMAGE. FOR ASSISTANCE OR ADDITIONAL INFORMATION CONSULT A QUALIFIED INSTALLER, SERVICE AGENCY OR THE GAS SUPPLIER.  
FAILURE TO FOLLOW THIS WARNING COULD RESULT IN PROPERTY DAMAGE, PERSONAL INJURY OR DEATH.

## **⚠ CAUTION**

If the furnace is shut down during the cold weather months, provisions must be taken to prevent freeze-up of all water pipes and water receptacles.

## **⚠ CAUTION**

Do NOT touch igniter. It is extremely hot.

## **⚠ CAUTION**

The combustion air for your furnace must be fresh uncontaminated air. Paints, varnishes, laundry bleaches, detergents, many household cleaners, water softening salts, adhesives, and all such products release fumes containing compounds which could lead to early heat exchanger and vent system deterioration. Do NOT store these types of products near your furnace.

## **⚠ CAUTION**

The combustion air for your furnace must be fresh uncontaminated air. Paints, varnishes, laundry bleaches, detergents, many household cleaners, water softening salts, adhesives, and all such products release fumes containing compounds which could lead to early heat exchanger and vent system deterioration. Do NOT store these types of products near your furnace.

## **⚠ CAUTION**

**Safety Hazard**  
Sharp Edge Hazard. Be careful of sharp edges on equipment or any cuts made on sheet metal while installing or servicing. Personal injury may result.

## **IMPORTANT FACTS**

The flow of combustion and ventilating air must not be obstructed from reaching the furnace. Air openings provided in the casing of the furnace must be kept free of obstructions which would restrict airflow, thereby affecting efficiency and safe operation of your furnace.

Also, air openings provided to the area in which the furnace is installed and the space around the furnace shall not be blocked or obstructed. Keep this in mind should you choose to remodel the area which contains your furnace. If additional insulation is added after the furnace is installed, the area around the furnace must be inspected to ensure it is free and clear of insulation. If this furnace is installed in an attic or other insulated space it must be kept free and clear of all insulating materials as some insulating materials are combustible.

Furnaces must have air for proper performance. There must be a free flow of fresh air sufficient for efficient combustion and safe ventilation of your furnace.

**Never store gasoline, combustible materials, or other flammable liquids or vapors near your furnace.**

Carbon monoxide, fire or smoke can cause serious bodily injury, death, and/or property damage.

A variety of potential sources of carbon monoxide can be found in a building or dwelling such as gas-fired clothes dryers, gas cooking stoves, water heaters, furnaces and fireplaces. The U.S. Consumer Product Safety Commission recommends that users of gas-burning appliances install carbon monoxide detectors as well as fire and smoke detectors, listed by a nationally recognized agency (e.g. Underwriters Laboratories or International Approval Services), to help alert dwelling occupants of the presence of fire, smoke or unsafe levels of carbon monoxide.

***NOTE: The manufacturer of your furnace does not test any detectors and makes no representations regarding any brand or type of detector.***

Installing and servicing heating equipment can be hazardous due to gas and electrical components. Only trained and qualified personnel should install, repair or service heating equipment.

Untrained personnel can perform basic maintenance functions such as cleaning and replacing filters. All other operations must be performed by trained service personnel.

Parts and controls of this furnace are unique. Should service or modification be required, be sure your servicer uses only factory authorized parts, kits, or accessories for this furnace.

If you experience a problem with the operation of your furnace, check the "Problem Solver" section of this manual before you call for a possibly unneeded service call.

## To Start the Furnace

### Lighting instructions.

Your furnace does not use a continuously burning pilot flame. Therefore, manually lighting your furnace is not required. Your furnace is equipped with an automatic ignition system. It uses a hot surface ignition device that automatically lights the burners each time the comfort control signals the furnace to start.

### **⚠ WARNING**

#### **BURN HAZARD**

**DO NOT ATTEMPT TO MANUALLY LIGHT THE FURNACE.**

### **⚠ CAUTION**

**If the furnace is shut down during the cold weather months, provisions must be taken to prevent freeze-up of all water pipes and water receptacles.**

1. Please read all safety information in this book before operating furnace.
2. Set comfort control to lowest setting. Turn off all electric power to furnace.
3. Remove the furnace front panel to gain access to the main gas valve.
4. Turn external main gas shutoff valve or the toggle switch located on the main gas valve inside the unit to the "OFF" position (see illustration on this page). If an external main gas shutoff valve is used, turn to "OFF" position (see illustration on next page). Allow 5 minutes for any gas within the unit to escape. LP gas being heavier than air may require forced ventilation. **If you smell gas STOP! Follow the "What To Do If You Smell Gas" instructions on the front cover of this book. If you don't smell gas, go to next step.**
5. Turn the external main gas shutoff valve and the toggle switch located on the main gas valve inside the unit to the "ON" position (see illustration on this page).

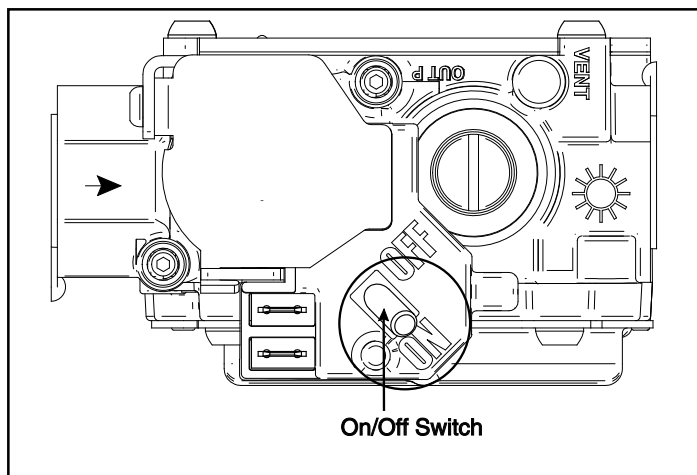

6. Replace the furnace front access panel.
7. Turn on main electrical supply and set comfort control to desired setting. Combustion blower will start and ignition device will start to heat up. After approximately 15 seconds main gas valve will open and burners will ignite.
8. When the comfort control is satisfied, main burners will extinguish.
9. If main burners fail to ignite turn off the main electrical supply power or lower the comfort control setting and wait 5 minutes.
10. Raise the comfort control setting and restore electrical supply power. Repeat steps 6 through 8.
11. If furnace still will not light, turn "OFF" all gas and electricity to unit and call servicer or gas supplier.

### **For complete shutdown.**

Turn the external main gas shutoff valve and the toggle switch on the main gas valve inside the unit to the "OFF" position. Disconnect electrical supply to unit.

Whenever your house is to be vacant, arrange to have someone inspect your house for proper temperature. If your furnace should fail to operate, damage could result, such as frozen water pipes.

### **Flame Roll-out Device.**

All models are equipped with a manual resetting rollout switch located near the burners. In case of flame roll-out, the switch trips automatically shutting off all flow of gas. The switch must be manually reset by pressing the red reset button on the top of the switch.

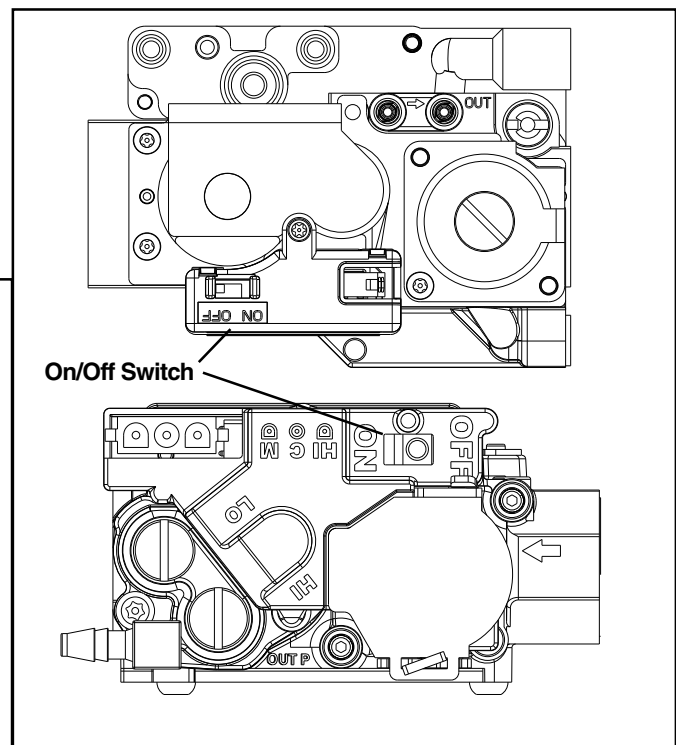

# User's Information

**NOTE THE LOCATION OF THE MANUAL MAIN GAS SHUTOFF VALVE FOR YOUR FURNACE.  
Have your installer or servicer show you the location if you have any questions.**

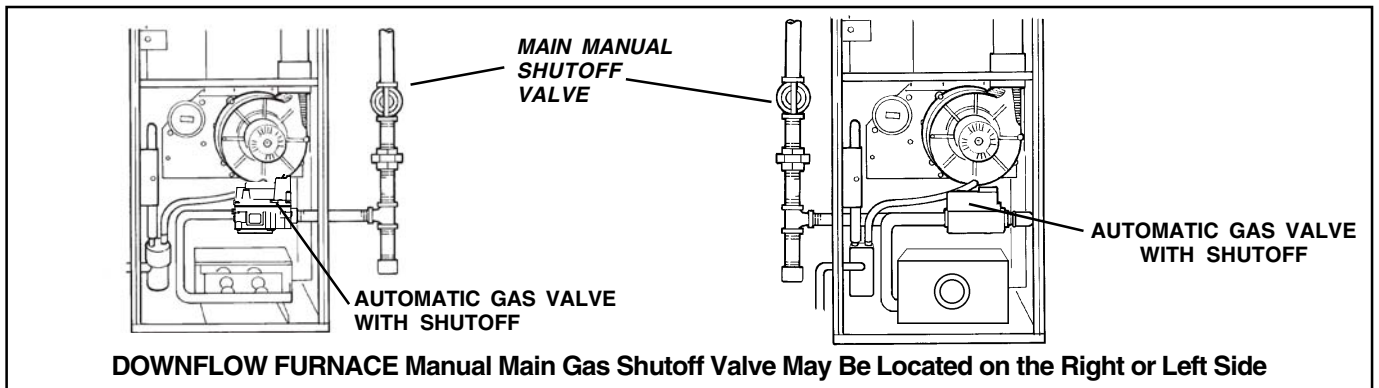
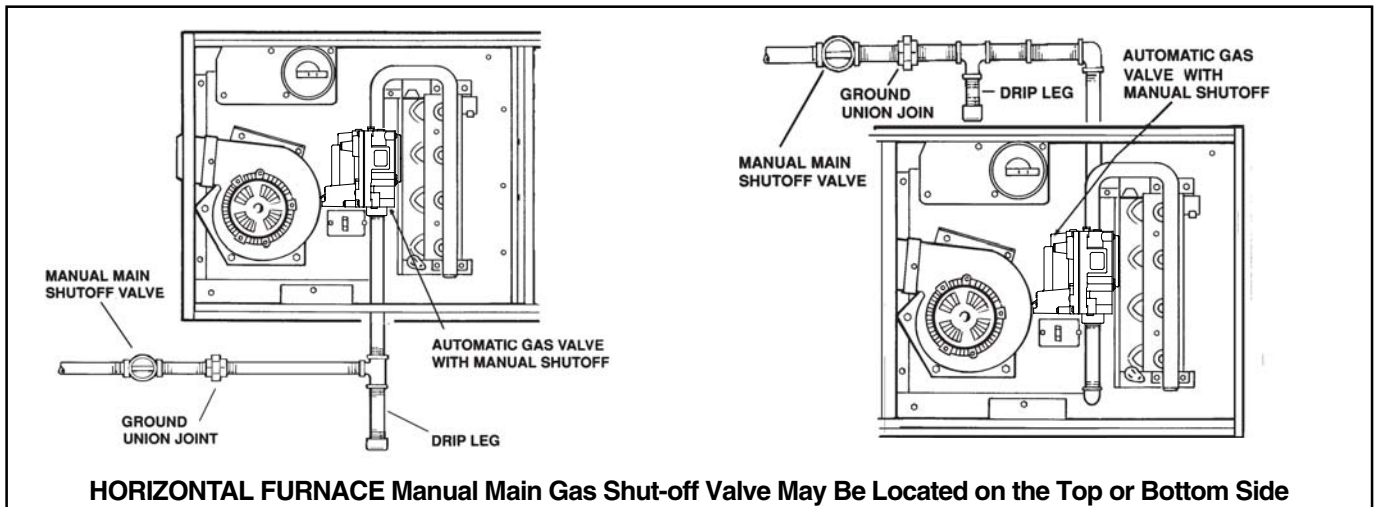
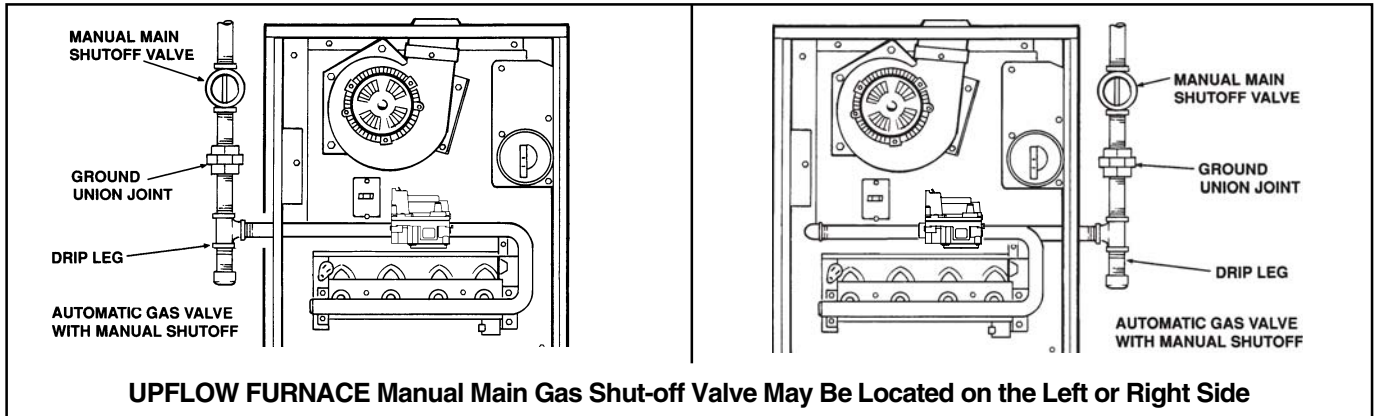

# User's Information

## Proper Maintenance

### AIR FILTERS

**NOTE:** *Filters are NOT included with all Furnaces, however; the Furnace should never be run without a filter.*

#### A clean filter saves money.

When the furnace circulates and filters the air in your home, dust and dirt particles build up on the filter. Excessive accumulation can block the airflow, forcing the unit to work harder to maintain desired temperatures. And the harder your unit has to work, the more energy it uses. So you pay more any time your system is running with a dirty filter.

### ⚠ CAUTION

**Never operate your unit for either heating or cooling with filters removed.**

Help ensure top efficiency by cleaning the filter once a month. Clean it twice a month during seasons when the unit runs more often.

You can clean the filter with a vacuum, OR you can wash it with a household detergent.

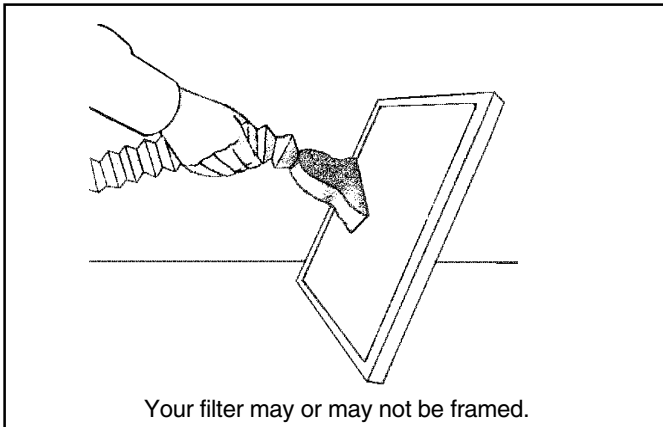

#### Replacing your filter.

When replacing your furnace filters, always use a high velocity type which are the same size as originally supplied. Filters are available from your dealer.

Where disposable filters are used, they must be a high velocity type which are the same size as originally supplied.

#### How to remove your filter.

### ⚠ WARNING

**ELECTRIC SHOCK HAZARD  
DISCONNECT POWER TO UNIT BEFORE REMOVING  
BLOWER DOOR.**

Upflow furnaces use a high velocity type air filter which may be located within the furnace blower compartment in either a **BOTTOM** or **SIDE** (left or right) return air inlet. The filter may be secured with filter retaining brackets (as shown) or a filter rack.

To clean or replace filters, remove blower access door, slide the filter from the filter rack or remove the filter from the retaining brackets. After cleaning, replace the filter in the same manner, making sure that the filter is secured in place in both the front and back filter retaining brackets, if present, or that the filter is securely slid all the way into the filter rack. Replace blower access door. A bottom return air inlet as shown features a 17" x 25" x 1" filter in the 17-1/2" wide furnace cabinets; a 20" x 25" x 1" filter in the 21" wide models; and a 24" x 25" x 1" filter in the 24-1/2" wide cabinet.

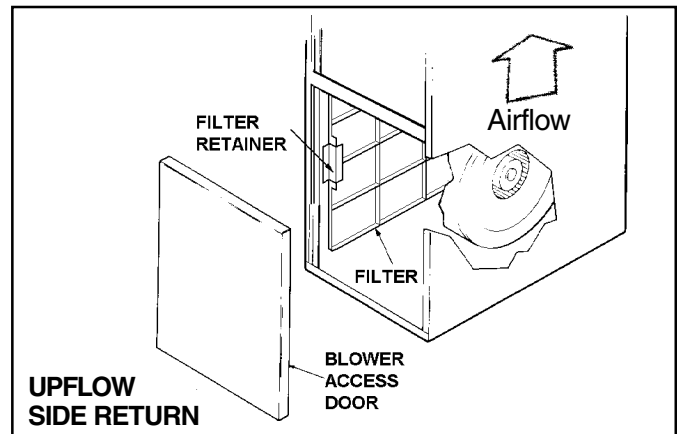
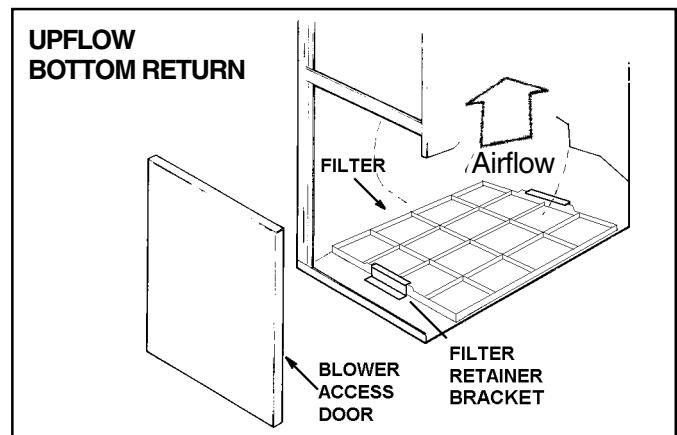

For vertical UPFLOW ONLY, a left or right return air inlet as above (left side shown) requires trimming of the factory supplied filter to 17" x 25" x 1" for both the 21" and 24-1/2" wide furnaces.

Air filters may also be located outside of the furnace using a **SIDE FILTER FRAME**.

# User's Information

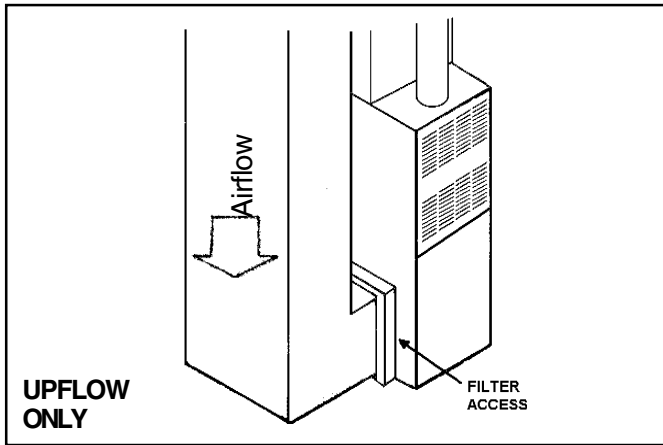

## Upflow/ Horizontal Furnace Filters

The Upflow/ Horizontal furnace when installed horizontally requires a horizontal filter kit. The filters may be located remote to the furnace or in the return air duct near the furnace. Check with your dealer for the location of your filters.

An upflow/horizontal furnace in horizontal return air filter application, as shown, features two 16" x 20" x 1" filters in the 17-1/2", 21" and 24-1/2" wide furnace cabinets.

To replace filters, remove the filter access door, lift the filter from the lower bracket and shift the filter to the side to free the top filter from the bracket and slide the filters out through the filter access door. After cleaning, replace the filters in the same manner making sure that the filters are secured in place in both top and bottom filter brackets. Replace filter access door.

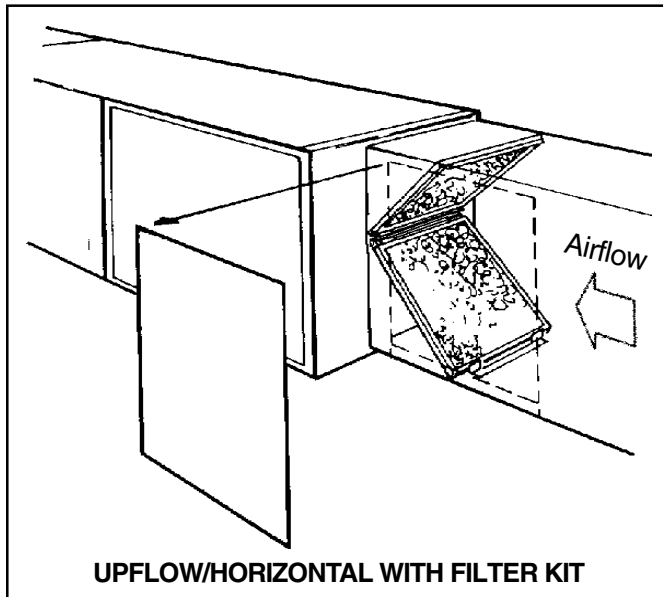

Air filters may also be located outside of the furnace using a remote filter grille. The filter grille could be in a hallway, wall, or in the ceiling. Check with your dealer for the exact location of your filter and the method of changing the filters.

| REQUIRED FILTERS - BOTTOM |                        |
|---------------------------|------------------------|
| CABINET WIDTH             | FILTER QUANTITY & SIZE |
| 17-1/2"                   | 1 - 17" X 25" X 1"     |
| 21"                       | 1 - 20" X 25" X 1"     |
| 24-1/2"                   | 1 - 24" X 25" X 1"     |

| REQUIRED FILTERS - SIDE ** |                        |
|----------------------------|------------------------|
| CABINET WIDTH              | FILTER QUANTITY & SIZE |
| 17-1/2"                    | 1 - 17" X 25" X 1"     |
| 21"                        | 1 - 17" X 25" X 1"     |
| 24-1/2"                    | 1 - 17" X 25" X 1"     |

\*\* ON UPFLOW 5 TON AIRFLOW MODELS, IF THE AIRFLOW REQUIREMENT EXCEEDS 1800 CFM, THESE MODELS WILL REQUIRE FILTERS ON BOTH SIDES OR 1 SIDE AND THE BOTTOM, OR JUST THE BOTTOM

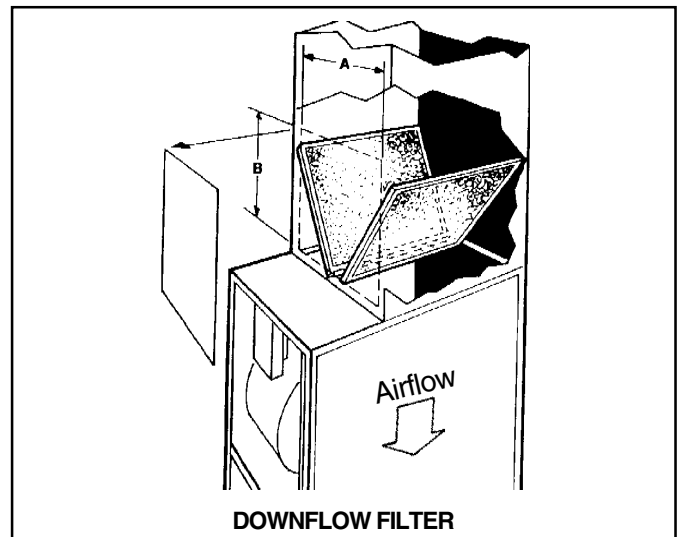

## UPFLOW (Vertical) FILTER TABLES

Downflow/ Horizontal furnaces are factory supplied with 2 standard size permanent type air filters which may be located remote to the furnace or in the return air duct. Check with your dealer for the location of your filters.

A downflow/ horizontal furnace return air filter application, as shown, features two 14" x 20" x 1" filters in the 17-1/2" wide furnace cabinets; or two 16" x 20" x 1" filters in the 21" and 24-1/2" wide furnace cabinets.

# User's Information

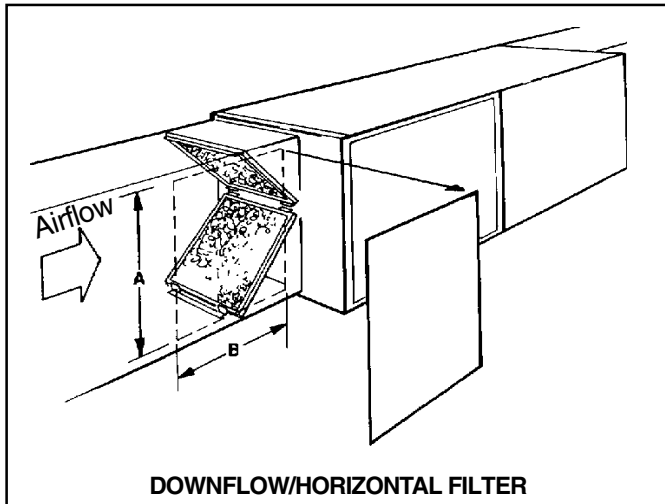

DOWNFLOW/HORIZONTAL FILTER

DOWNFLOW (Vertical) FILTER TABLE

| REQUIRED FILTERS - DOWNFLOW |                        |
|-----------------------------|------------------------|
| CABINET WIDTH               | FILTER QUANTITY & SIZE |
| 17-1/2"                     | 2 - 14" X 20" X 1"     |
| 21"                         | 2 - 16" X 20" X 1"     |
| 24-1/2"                     | 2 - 16" X 20" X 1"     |

## The Problem Solver

### ⚠ WARNING

**CARBON MONOXIDE POISONING HAZARD**  
**DO NOT ATTEMPT TO CHANGE THE VENTING SYSTEM. FAILURE TO FOLLOW THE INSTALLATION AND OPERATION INSTRUCTIONS FOR THE VENTING SYSTEM'S OPERATION COULD RESULT IN CARBON MONOXIDE POISONING OR DEATH.**

A furnace is not a household appliance. It is complex and requires professional maintenance and repair. Attempts at "do-it-yourself" repairs on an in-warranty unit may void the remainder of your warranty.

Other than performing the simple maintenance recommended in this manual, you should not attempt to make any adjustments to your furnace. Your dealer will be able to take care of any questions or problems you may have. A periodic inspection of your furnace should be made by a qualified service agency at the start of each heating season.

In the event that electrical, fuel, or mechanical failures occur, you should immediately turn the gas supply off at the manual gas valve located on the gas pipe leading to the furnace. Also, turn off electrical power to the furnace and contact a qualified service agency.

**Keep your furnace looking like new for years.**

Clean the enamel finish of your furnace with ordinary soap and water. For stubborn grease spots, use a household detergent. Lacquer thinner or other synthetic solvents may damage the finish.

**Save time and money. Before calling for service, check the following:**

| Problem  | Possible Trouble   | Possible Remedy   |
|--|--|---|
| No Heating --<br>Blower does not operate                 | 1. Thermostat set incorrectly.<br>2. Blown fuse or tripped circuit breaker.<br>3. Burner does not ignite.<br>4. Main gas line turned off.<br>5. Blower door removed or ajar.<br>6. Lockout | 1. Adjust thermostat. See operating instructions.<br>2. Replace or reset protective device or call for servicer.<br>3. Call Servicer.<br>4. Have gas company check.<br>5. Close door securely to restore power to blower and gas valve.<br>6. Cycle power twice in thirty seconds for furnaces other than *UH3 and *DH3.<br>Cycle power once for furnace models *UH3 and *DH3 |
| Insufficient Heating --<br>Blower operates continuously. | 1. Dirty air filters.<br>2. Blocked supply or return registers.  | 1. Clean or replace filters.<br>2. Make sure registers are open and no obstacles are blocking off the air   |
| Unusual Noise  |  | Call your servicer.   |



## Regular Dealer Maintenance

Regular maintenance to be performed by a qualified service professional ONLY.

The following warning complies with State of California law, Proposition 65.

### **WARNING**

#### **Hazardous Gases!**

Exposure to fuel substances or by-products of incomplete fuel combustion is believed by the state of California to cause cancer, birth defects, or other reproductive harm.

### **WARNING**

#### **HAZARDOUS GASES**

UNIT IS EQUIPPED WITH A BLOWER DOOR SWITCH WHICH CUTS POWER TO BLOWER AND GAS VALVE CAUSING SHUTDOWN WHEN DOOR IS REMOVED. UNIT MUST NOT BE ALTERED TO ALLOW OPERATION WITH THE BLOWER DOOR REMOVED. OPERATION WITH DOORS REMOVED OR AJAR CAN PERMIT THE ESCAPE OF DANGEROUS FUMES. ALL PANELS MUST BE SECURELY CLOSED AT ALL TIMES FOR SAFE OPERATION OF THE FURNACE.

### **WARNING**

#### **ELECTRIC SHOCK HAZARD**

IN THE EVENT THAT ELECTRICAL, FUEL OR MECHANICAL FAILURES OCCUR, THE OWNER SHOULD IMMEDIATELY TURN OFF THE GAS SUPPLY AT THE MANUAL GAS VALVE LOCATED ON THE GAS PIPE LEADING TO THE FURNACE AND ELECTRICAL POWER TO THE FURNACE AND CONTACT SERVICER. FAILURE TO FOLLOW THIS WARNING COULD RESULT IN PROPERTY DAMAGE, PERSONAL INJURY OR DEATH.

### **CAUTION**

Do NOT touch igniter. It is extremely hot.

### **WARNING**

#### **EXPLOSION HAZARD**

SHOULD OVERHEATING OCCUR, OR THE GAS SUPPLY FAIL TO SHUT OFF, SHUT OFF THE MANUAL GAS VALVE TO THE FURNACE BEFORE SHUTTING OFF THE ELECTRICAL SUPPLY.

FAILURE TO FOLLOW THIS WARNING COULD RESULT IN PROPERTY DAMAGE, PERSONAL INJURY OR DEATH.

1. GENERAL INSPECTION – Examine the furnace installation for the following items:
  - a. All flue product carrying areas external to the furnace (i.e. chimney, vent connector) are clear and free of obstruction.
  - b. The vent connector is in place, slopes upward and is physically sound without holes or excessive corrosion.
  - c. The return air duct connection(s) is physically sound, is sealed to the furnace and terminates outside the space containing the furnace.
  - d. The physical support of the furnace should be sound without sagging, cracks, gaps, etc., around the base so as to provide a seal between the support and the base.
  - e. There are no obvious signs of deterioration of the furnace.

# User's Information

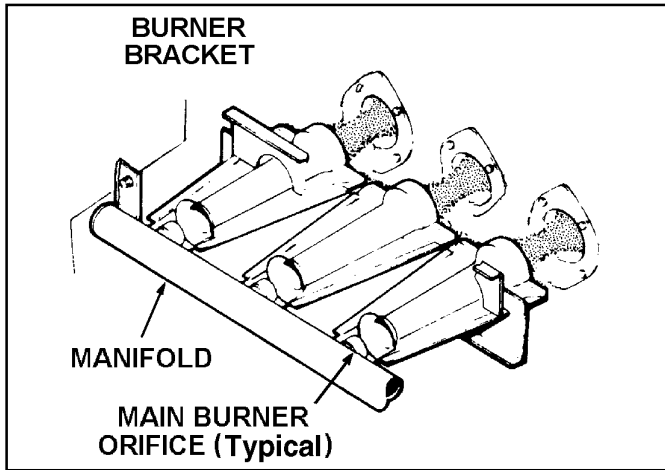

**NOTE:** On LP (propane) units, some light yellow tipping of the outer mantle is normal. Inner mantle should be bright blue. Natural gas units should not have any yellow tipped flames. This condition indicates that a service call is required. For best operation, burners must be cleaned annually using brushes and vacuum cleaner.

**NOTE:** On LP (propane) units, due to variations in BTU content and altitude, servicing may be required at shorter intervals.

2. **BLOWERS** – The blower size and speed determine the air volume delivered by the furnace. The blower motor bearings are factory lubricated and under normal operating conditions usually do not require servicing. Annual cleaning of the blower wheel and housing is recommended for maximum air output, and this must be performed only by a qualified servicer or service agency.
3. **IGNITER** – This unit has a special hot surface direct ignition device that automatically lights the burners. Please note that it is very fragile and should be handled with care.
4. **BURNER** – Gas burners do not normally require scheduled servicing, however, accumulation of foreign material may cause a yellowing flame or delayed ignition. Either condition indicates that a service call is required. For best operation, burners must be cleaned annually using brushes and vacuum cleaner.

Turn off gas and electric power supply. To clean burners, remove top burner bracket and lift burner from orifice.

**NOTE:** Be careful NOT to break igniter when removing burners.

Clean burners with brush and/ or vacuum cleaner. Re-assemble parts by reversal of the above procedure.

5. **HEAT EXCHANGER / FLUE PIPE** – These items must be inspected for signs of corrosion, and/ or deterioration at the beginning of each heating season by a qualified service technician and cleaned annually for best operation.
6. **CIRCUIT PROTECTION** – If blower or gas valve fail to operate, the cause could be the circuit breaker or a loose or blown fuse. Replace fuse or reset circuit breaker.
7. **OPERATION** – Your warm air furnace should not be operated in a corrosive atmosphere. Paint solvents, cleaning chemicals, spray propellants, and bleaches should not be used in the vicinity of the furnace during normal operation.
8. **CONDENSATE DRAINS** – If you have a cooling coil installed with your furnace, condensate drains should be checked and cleaned periodically to assure that condensate can drain freely from coil to drain. If condensate cannot drain freely water damage could occur. Furnace drain should also be checked & cleaned at the start of each heating season.
9. **AIR CIRCULATION** – To ensure increased comfort, the blower on this unit may be operated continuously for both heating and cooling. This will result in constantly filtered air and aid in maintaining more even temperatures by avoiding temperature stratification throughout the conditioned area. To accomplish constant air circulation, set your comfort control fan selector to "ON". Continuous fan mode during COOLING operation may not be appropriate in humid climates. If the indoor air exceeds 60% relative humidity or simply feels uncomfortably humid, it is recommended that the fan only be used in the "AUTO" mode."



Trane  
6200 Troup Highway  
Tyler, TX 75707

For more information contact your local dealer.

The manufacturer has a policy of continuous product and product data improvement; it reserves the right to change design and specifications without notice.

## Limited Warranty High Efficiency Condensing Gas Furnace UH3, DH3, UX2, DX2, UH2, DH2, UX1, DX1, UX1-H, DX1-H, UX, DX, UY and DY

(First letter may be preceded by an "A" or "T") (Parts Only)

### Models Less Than 20 Tons for Residential Use\*

This limited warranty is extended by Trane U.S. Inc., to the original purchaser of the specified models for life, under the conditions set forth below or to any succeeding owner for a period of twenty (20) years from the date of installation, as originally affixed, for the original owner. This limited warranty applies to products purchased and retained for use within the U.S.A. and Canada.

#### Limited Warranty

If any part of your furnace fails because of a manufacturing defect within five (5) years from the date of original purchase, Warrantor will furnish without charge the required replacement part F.O.B. nearest Parts Distribution point. Any local transportation, related service labor, air filters, and diagnosis calls, are not included.

#### Limited Lifetime Warranty

The primary and secondary heat exchanger, when installed to serve a single family residence or single condominium, is warranted to the original purchaser for life, provided the installation is in the original purchaser's primary, uninterrupted residence from the date of purchase until discovery of a defect in the primary heat exchanger or secondary heat exchanger. The heat exchanger is warranted to a successor purchaser for a period of twenty (20) years from the date of original installation of the furnace, subject to proof of original purchase. Warrantor WILL AT ITS OPTION provide either a heat exchanger including secondary heat exchanger without charge F.O.B. nearest Parts Distribution point, or allow a credit in the amount of the then current wholesale price of an equivalent heat exchanger toward the purchase price of a comparable heating unit. Any local transportation, related service labor, air filters, and diagnosis calls, are not included.

This limited warranty does not cover failure of your gas furnace if it is damaged while in your possession, damage caused by unreasonable use of the gas furnace and/or damage from **failure to properly maintain** the gas furnace as set forth in the Use and Care manual (**see Proper Maintenance section**).

**THE LIMITED WARRANTY AND LIABILITY SET FORTH HEREIN ARE IN LIEU OF ALL OTHER WARRANTIES AND LIABILITIES, WHETHER IN CONTRACT OR IN NEGLIGENCE, EXPRESS OR IMPLIED, IN LAW OR IN FACT, INCLUDING IMPLIED WARRANTIES OF MERCHANTABILITY AND FITNESS FOR PARTICULAR USE, AND IN NO EVENT SHALL WARRANTOR BE LIABLE FOR ANY INCIDENTAL OR CONSEQUENTIAL DAMAGES.**

Some states do not allow limitations on how long an implied limited warranty lasts or do not allow the exclusion or limitation of incidental or consequential damages, so the above limitation or exclusion may not apply to you. This limited warranty gives you specific legal rights, and you may also have other rights which vary from state to state.

Parts will be provided by our factory organization through an authorized service organization in your area listed in the yellow pages. If you wish further help or information concerning this limited warranty, contact:

Trane  
P. O. Box 9010, Tyler, TX 75711-9010  
Attention: Manager, Field Operations Excellence

Or visit our website: [www.trane.com/residential](http://www.trane.com/residential)

TW-1013-4707

\* This limited warranty is for residential usage of this equipment and not applicable when this equipment is used for a commercial application. A commercial use is any application where the end purchaser uses the product for other than personal, family or household purposes.

The limited warranties displayed in this publication and/or on ComfortSite™ may not accurately reflect the actual limited warranty that shipped with the product.

# User's Information

## **Limited Warranty Induced Draft Gas Furnace UC1, DC1, UX1, DX1, UX1-H, DX1-H, UX, DX, UY, DY, UD-R, DD-R, UD-RV, DD-RV, UD1-H, DD1-H, UD1, DD1, UE1, DE1, UH3, DH3, UX2, DX2, UH2, DH2, UD2 and DD2**

---

### **Models Less Than 20 Tons for Commercial Use\***

(First letter may be preceded by an "A" or "T") (Parts Only)

This warranty is extended by Trane U.S. Inc., to the original purchaser and to any succeeding owner of the real property to which the Gas Furnace is originally affixed, and applies to products purchased and retained for use within the U.S.A. and Canada. There is no warranty against corrosion, erosion or deterioration.

If any part of your Gas Furnace fails because of a manufacturing defect within one year from the date of the original purchase, Warrantor will furnish without charge the required replacement part.

This limited warranty does not cover failure of your gas furnace if it is damaged while in your possession, damage caused by unreasonable use of the gas furnace and/or damage from **failure to properly maintain** the gas furnace as set forth in the Use and Care manual (**see Proper Maintenance section**).

In addition, if the steel heat exchanger fails because of a manufacturing defect within the second through twentieth year from the date of original purchase, Warrantor shall furnish without charge a replacement heat exchanger. Warrantor's obligations and liabilities under this warranty are limited to furnishing F.O.B. Warrantor factory or warehouse replacement parts for Warrantor's products covered under this warranty. No liability shall attach to Warrantor until products have been paid for and then liability shall be limited solely to the purchase price of the equipment under warranty shown to be defective.

**THE WARRANTY AND LIABILITY SET FORTH HEREIN ARE IN LIEU OF ALL OTHER WARRANTIES AND LIABILITIES, WHETHER IN CONTRACT OR IN NEGLIGENCE, EXPRESS OR IMPLIED, IN LAW OR IN FACT, INCLUDING IMPLIED WARRANTIES OF MERCHANTABILITY AND FITNESS FOR PARTICULAR USE, AND IN NO EVENT SHALL WARRANTOR BE LIABLE FOR ANY INCIDENTAL OR CONSEQUENTIAL DAMAGES.**

Some states do not allow limitations on how long an implied warranty lasts or do not allow the exclusion or limitation of incidental or consequential damages, so the above limitation or exclusion may not apply to you. This warranty gives you specific legal rights, and you may also have other rights which vary from state to state.

Trane  
P.O. Box 9010  
Tyler, TX 75711-9010  
Attention: Manager, Field Operations Excellence

TW-1012-4707

\* This warranty is for commercial usage of said equipment and not applicable when the equipment is used for a residential application. Commercial use is any application where the end purchaser uses the product for other than personal, family or household purposes.

The limited warranties displayed in this publication and/or on ComfortSite™ may not accurately reflect the actual limited warranty that shipped with the product.

As an **ENERGY STAR** Partner, American Standard Inc., has determined that this product meets the **ENERGY STAR** guidelines for energy efficiency.